

# Technical information

## Diptank 60



### Characteristics

- Cycle time: 3-5 seconds.
- Maximum loading capacity: 60 kg
- Digital temperature control
- Immersion depth: 220 mm
- Hydraulic operation
- Optimal hygiene
- Stainless steel casing
- Isolation balls to prevent evaporation.



| Specs                            | Diptank 60                             |
|----------------------------------|--|
| Chamber LxWxH (mm)               | 500x600x220                            |
| Machine LxWxH (mm)               | 770x790x1320                           |
| Voltage                          | 400V-3-50Hz 230V-3-50Hz<br>220V-3-60Hz |
| Machine cycle 50 Hz/60 Hz (sec.) | 3 - 5                                  |
| Power (kW)                       | 9,0                                    |
| Weight (kg)                      | 120                                    |

### Dimensions mm

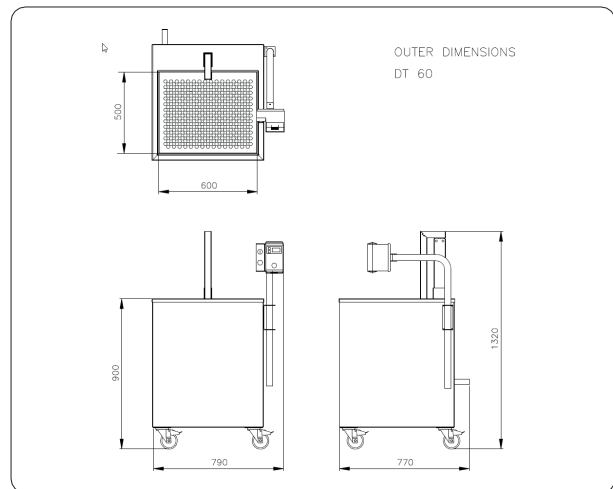

**Henkelman Aust**  
 Unit 3,14-16  
 Cairns Street, Loganholme  
 QLD Australia 4129  
 (07) 3806 5972

**Sales/Service/Tech Support**  
[sales@henkelman.com.au](mailto:sales@henkelman.com.au)  
 Office Hours: 8am – 4pm  
 Open Monday - Friday

# Technical information

## Diptank 100



### Characteristics

- Cycle time: 3-5 seconds.
- Maximum loading capacity: 60 kg
- Digital temperature control
- Immersion depth: 220 mm
- Hydraulic operation
- Optimal hygiene
- Stainless steel casing
- Isolation balls to prevent evaporation.



| Specs                            | Diptank 100                            |
|----------------------------------|--|
| Chamber LxWxH (mm)               | 600x800x220                            |
| Machine LxWxH (mm)               | 880x1000x1320                          |
| Voltage                          | 400V-3-50Hz 230V-3-50Hz<br>220V-3-60Hz |
| Machine cycle 50 Hz/60 Hz (sec.) | 3 - 5                                  |
| Power (kW)                       | 15,0                                   |
| Weight (kg)                      | 155                                    |

### Dimensions mm

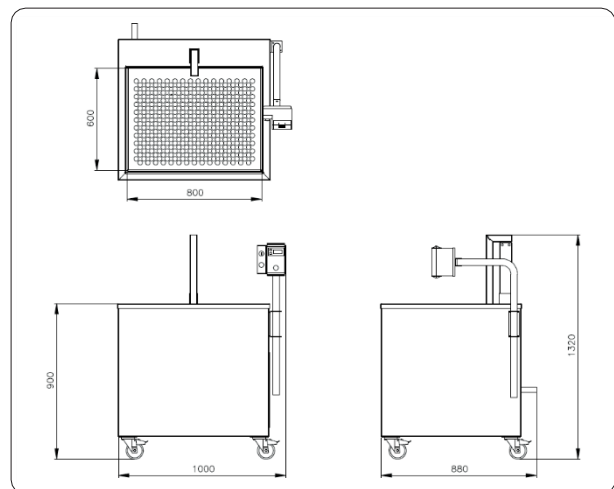

**Henkelman Aust**  
Unit 3,14-16  
Cairns Street, Loganholme  
QLD Australia 4129  
(07) 3806 5972

**Sales/Service/Tech Support**  
[sales@henkelman.com.au](mailto:sales@henkelman.com.au)  
Office Hours: 8am – 4pm  
Open Monday - Friday

# Technical information

## Diptank 200A



### Characteristics

- Automatic platform with conveyor belt
- Digital temperature control
- Pneumatic operation
- Stainless steel casing
- Optimal hygiene
- Maximum loading capacity: 30 kg
- Immersion depth: 200 mm
- Immersion time: 3-5 seconds (adjustable)
- Cycle time: 22 seconds.
- Compressed air consumption 50 l/min 6 bar
- Fully insulated.
- Vapor exhaust  $\varnothing$ 125 mm, excl. fan.
- Automatically controlled water supply
- Water drain
- Automatic water level control
- Built-in scale protection
- Transfer function (passthrough without dipping)
- Time switch to preheat water.
- Potential-free contact



| Specs                            | Diptank 200A                 |
|----------------------------------|------------------------------|
| Chamber LxWxH (mm)               | 575x1098x200                 |
| Machine LxWxH (mm)               | 1170x1700x1350               |
| Voltage                          | 400V-3-50 Hz<br>380V-3-60 Hz |
| Machine cycle 50 Hz/60 Hz (sec.) | 22                           |
| Power (kW)                       | 20,0                         |
| Weight (kg)                      | 310                          |

### Dimensions mm

