

Technical information

Titaan 110



Characteristics

- Supplied with two sealing bars as standard (front/left)
- Double seal as standard (two sealing wires). Optional at no extra cost: Cut-off seal/Wide seal (10 mm)
- Easy-to-remove silicone holders for easy cleaning.
- ACS control as standard
- Sensor control
- Soft Air as standard to protect the product and vacuum bag.
- Stainless steel casing and flat working plate
- Automatic lid (with foot pedal)
- Supplied with a removable internal conveyor belt to discharge the product.
- Single insert plate to raise the internal conveyor belt.
- IP-65 classification

Options

- Two sealing bars (front/right)
- 1-2 Cut-off seal/Bi-Active seal
- 100 or 300 m³/h pump
- Liquid control
- Connection for external pump
- Manual roller conveyor

Accessories

- Thermal label printer
- Maintenance set for standard maintenance



Specs	Titaan 110	
Chamber LxWxH (mm)	620x1050x190	
Machine LxWxH (mm)	947x1200x1150	
Voltage	400V-3-50Hz 230V-3-50Hz 220V-3-60Hz 200V-3-50/60Hz	
Pump capacity 50 Hz/60 Hz (m ³)	160 / 192	
Machine cycle 50 Hz/60 Hz (sec.)	15 - 33 / 13 - 29	
Power (kW)	4,0 - 4,5	
Weight (kg)	511	
Net seal length (mm)	1 x 1090, 1 x 620	
Sealing bar configuration - standard - option	standaard 	option

Dimensions mm

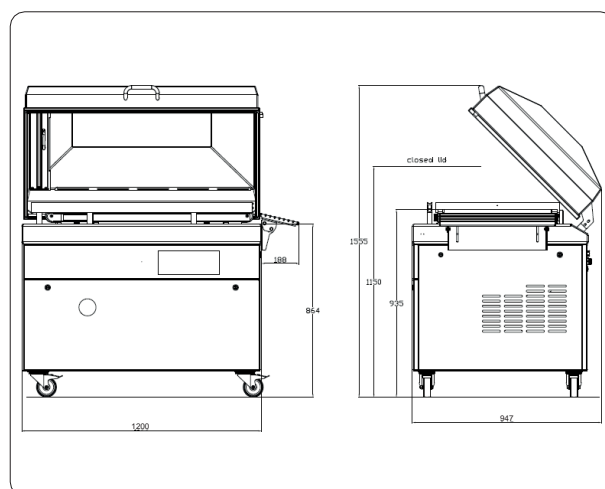

Technical information

Titaan 2-90

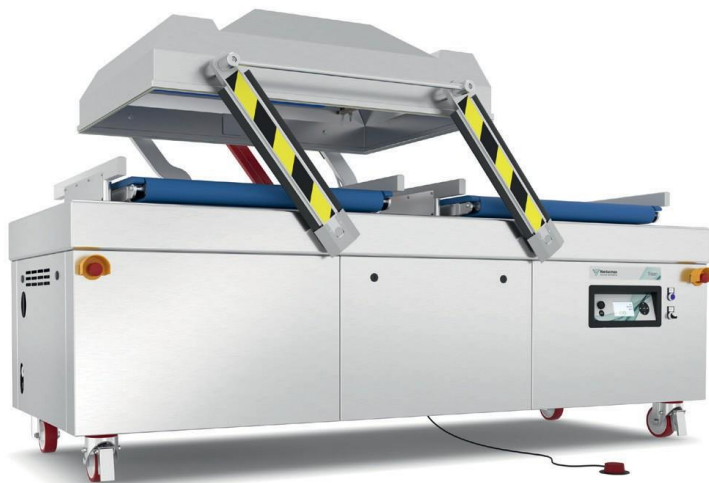

Characteristics

- Supplied with two sealing bars as standard (left/ right)
- Double seal as standard (two sealing wires).
Optional at no extra cost: Cut-off seal/Wide seal (10 mm)
- Easy-to-remove silicone holders for easy cleaning.
- ACS control as standard
- Sensor control
- Soft Air as standard to protect the product and vacuum bag.
- Stainless steel casing and flat working plate
- Automatic lid (automatic or with foot pedal)
- Supplied with two removable internal conveyor belts to discharge the product.
- Spacer set to raise the internal conveyor belts.
- IP-65 classification

Options

- 1-2 Cut-off seal
- Liquid control
- Connection for external pump
- Extra sealing capacity

Accessories

- Thermal label printer
- External conveyor belt 600 x 3000 mm
- Maintenance set for standard maintenance



Specs	Titaan 2-90
Chamber LxWxH (mm)	840x890x220
Machine LxWxH (mm)	1061x2420x1150
Voltage	400V-3-50Hz 230V-3-50Hz 220V-3-60Hz 200V-3-50/60Hz
Pump capacity 50 Hz/60 Hz (m3)	300 / 360
Machine cycle 50 Hz/60 Hz (sec.)	15 - 37 / 13 - 33
Power (kW)	5,5
Weight (kg)	850
Net seal length (mm)	2 x 828
Standard sealing bar configuration	

Dimensions mm

